



For North American Market

INDUSTRIAL DIESEL ENGINE

KUBOTA SUPER MINI SERIES (2-cylinder)

Z482-E3B



RATED POWER

9.9kW@3600rpm

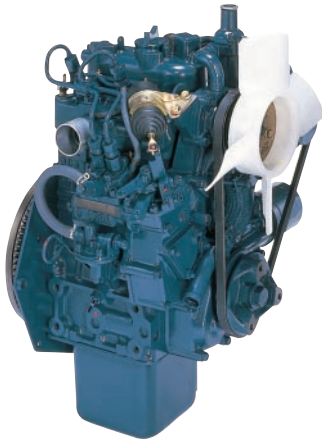

Photograph may show non-standard equipment.

PERFORMANCE CURVE

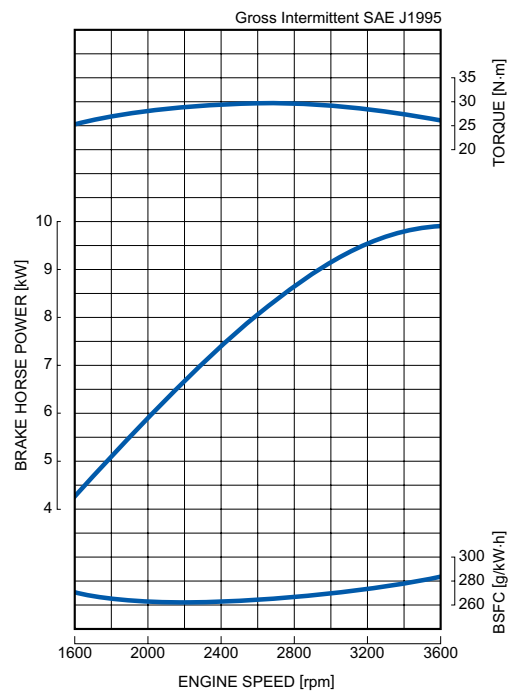

FEATURES and BENEFITS

Emissions

- Kubota Super Mini Series, the most compact multi-cylinder liquid cooled industrial diesel engines, complies with EPA Tier 4 emissions regulations. These are the most stringent emissions regulations in the world in this class.

Durable Power

- The Kubota Super Mini Series has been chosen as a power source for a variety of applications since it was first launched 25 years ago. It has become the benchmark in the compact diesel engine market.
- The Z482 engine offers a seamless transition from Tier 2 to Tier 4 by totally maintaining the same performance and physical characteristics of the previous Tier 2 engines.

Clean and Quiet Power

- Kubota's original E-TVCS (Three Vortex Combustion System) has been improved. The combustion chamber was optimized to achieve a 50% lower particulate matter (PM) level in such a small size range.

GENERAL SPECIFICATION

Model		Z482-E3B
Emission Regulation		Tier 4
Type		Vertical 4-cycle Liquid Cooled Diesel
Number of Cylinders		2
Bore	mm (in)	67 (2.64)
Stroke	mm (in)	68 (2.68)
Displacement	L (cu.in)	0.479 (29.23)
Combustion System		IDI
Intake System		Naturally Aspirated
Maximum Speed	rpm	3600
Output: Gross Intermittent (Industrial Use)	kW	9.9
	hp	13.3
	ps	13.5
Direction of Rotation		Counterclockwise Viewed on Flywheel
Oil Pan Capacity	L (gal)	2.5 (0.66)
Starter Capacity	V-kW	12-0.8
Alternator Capacity	V-A	12-12.5
Output: Stand-by (Generator Use)	kW	8.9
	hp	11.9
	ps	12.1
Output: Continuous (Generator Use)	kW	8.1
	hp	10.9
	ps	11.0
Length	mm (in)	360.6 (14.20)
Width	mm (in)	404.0 (15.91)
Height (1)	mm (in)	564.1 (22.21)
Height (2)	mm (in)	219.0 (8.62)
Dry Weight	kg (lb)	53.1 (117.1)

*Specification is subject to change without notice.

*Output: Gross Intermittent SAE J1995

*Output: Stand-by, Continuous ISO 3046

*Dry weight is according to Kubota's standard specification.
When specification varies, the weight will vary accordingly.

DIMENSIONS

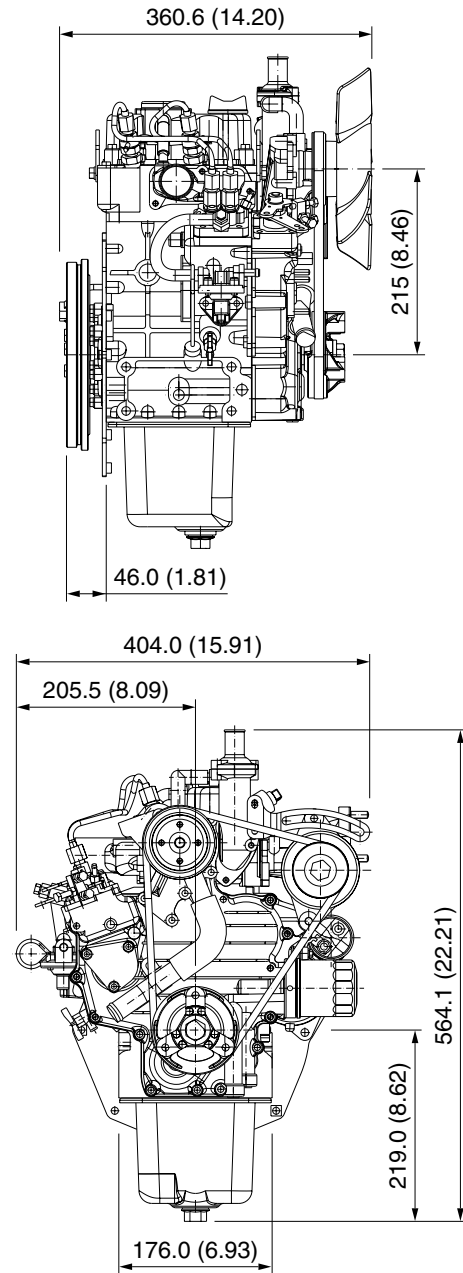

Your Driving Force
KUBOTA ENGINE

KUBOTA Corporation

2-47, Shikitsuhigashi 1-chome, Naniwa-ku, Osaka, 556-8601 Japan
Fax: 06-6648-3521

<http://www.engine.kubota.ne.jp>